

OWNER'S MANUAL

Model No.
16516626

Upright Cycle

- Assembly
- Operation
- Exercise
- Parts
- Warranty

CAUTION:
You must read and understand this owner's manual before operating unit.

EVERLAST

UPRIGHT CYCLE

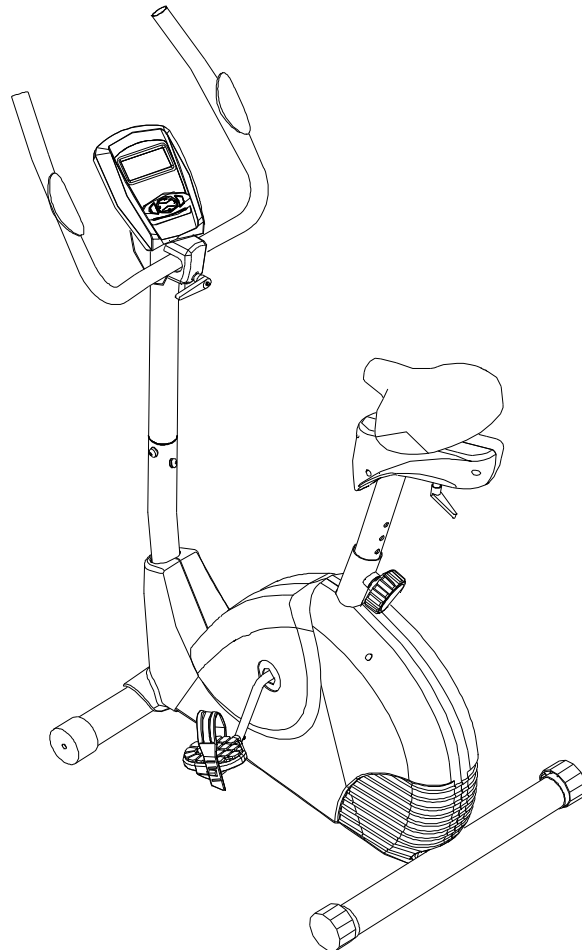

RETAIN FOR FUTURE REFERENCE

MAURICE PINCOFFS CANADA INC. 6050 DON MURIE STREET, NIAGARA FALLS, ONTARIO L2E 6X8

Manufacture's One-Year Limited Warranty

Your **EVERLAST** Upright Cycle is warranted for one year from the date of purchase against defects in material when used for the purpose intended, under normal conditions and provided it receives proper care. Any part found defective or missing will be sent at no cost when returned in accordance with the terms of this warranty.

This warranty is not transferable and is extended only to the original owner.

The warranty shall not apply to exercise units which are (1) used for commercial or other income producing purposes, or (2) subject to misuse, neglect, accident or unauthorized repair and alterations.

This warranty provided herein is lieu of all other express warranties, any implied warranties, including any implied warranties of merchantability of fitness for particular purpose, are limited in duration to the first 12 months from date of purchase. All other obligations or liabilities, including liability for consequential damages are hereby excluded.

REPAIR PARTS AND SERVICE

All of the parts for the cycle shown in figure can be ordered from Maurice Pincoffs Canada Inc. 6050 DON MURIE STREET, NIAGARA FALLS, ONTARIO L2E 6X8. When ordering parts, the parts will be sent and billed at the current prices. Prices may be subject to change without notice. Check or money order must accompany all orders. Standard hardware items are available at your local hardware store.

To ensure prompt and correct handling of any errors, or to answer any questions, please call our Toll Free number: 1-888-707-1880, or local number 1-905-353-8955 or fax 1-905-353-8968 or email customerservice@pincoffs.ca. Office hours are from 8:30 AM to 5:00 PM Monday to Friday Eastern Standard Time. [Visit us at www.pincoffs.ca](http://www.pincoffs.ca).

Always include the following information when ordering parts

- I Model number
- I Name of each part
- I Part number of each part

TABLE OF CONTENTS

WARRANTY	1	EXPLODED DIAGRAM	13
SAFETY PRECAUTIONS	2	PARTS LIST	14-16
PRE-ASSEMBLY CHECK LIST	3	TROUBLE SHOOTING	17
HARDWARE PACKING LIST	4	TRAINING GUIDELINES	18-20
ASSEMBLY INSTRUCTION	5-8	EXERCISE ROUTINE	21-22
COMPUTER INSTRUCTION	9-12		

SAFETY PRECAUTIONS

Thank you for purchasing our product. Even though we go to great efforts to ensure the quality of each product we produce, occasional errors and /or omissions do occur. In any event should you find this product to have either a defective or a missing part please contact us for a replacement.

This product has been designed for home use only. Product liability and guarantee conditions will not be applicable to products being subjected to professional use or products being used in a gym center.

This exercise equipment was designed and built for optimum safety. However, certain precautions apply whenever you operate a piece of exercise equipment. Be sure to read the entire manual before assembly and operation of this machine. Also, please note the following safety precautions:

1. Read the OWNER'S OPERATING MANUAL and all accompanying literature and follow it carefully before using your upright cycle.
2. If dizziness, nausea, chest pains, or any other abnormal symptoms are experienced while using this equipment, STOP the workout at once. CONSULT A PHYSICIAN IMMEDIATELY.
3. Inspect your exercise equipment prior to exercising to ensure that all nuts and bolts are fully tightened before each use.
4. The upright cycle must be regularly checked for signs of wear and damage. Any part found defective must be replaced with a new part from the manufacturer.
5. Fitness equipment must always be installed on a flat surface, It is recommended to use an equipment mat to prevent the unit from moving while it is being used, which could possibly scratch or damage the surface of your floor.
6. No changes must be made which might compromise the safety of the equipment.
7. It is recommended to have a minimum of 2' safe clearance around the exercise equipment while in use.
8. Keep children and pets away from this equipment at all times while exercising.
9. Warm up 5 to 10 minutes before each workout and cool down 5 to 10 minutes afterward. This allows your heart rate to gradually increase and decrease and will help prevent you from straining muscles.
10. Never hold your breath while exercising. Breathing should remain at a normal rate in conjunction with the level of exercise being performed
11. Always wear suitable clothing and footwear while exercising. Do not wear loose fitting clothing that could become entangled with the moving parts of your upright cycle.
12. Care must be taken when lifting or moving the equipment, so as not to injure your back. Always use proper lifting techniques.
13. User weight should not exceed 275 lbs.
14. Tie all long hair back.
15. Remove all personal jewelry before exercising.
16. After eating, allow 1-2 hours before exercising as this will help to prevent muscle strain.
17. Injuries may result from incorrect or excessive training and using the equipment otherwise than as directed or recommended by your doctor.

WARNING:

BEFORE BEGINNING ANY EXERCISE PROGRAM CONSULT YOUR PHYSICIAN. THIS IS ESPECIALLY IMPORTANT FOR INDIVIDUALS OVER THE AGE OF 35 OR PERSONS WITH PRE-EXISTING HEALTH PROBLEMS. READ ALL INSTRUCTIONS BEFORE USING ANY FITNESS EQUIPMENT. WE ASSUME NO RESPONSIBILITY FOR PERSONAL INJURY OR PROPERTY DAMAGE SUSTAINED BY OR THROUGH THE USE OF THIS PRODUCT.

PRE-ASSEMBLY CHECK LIST

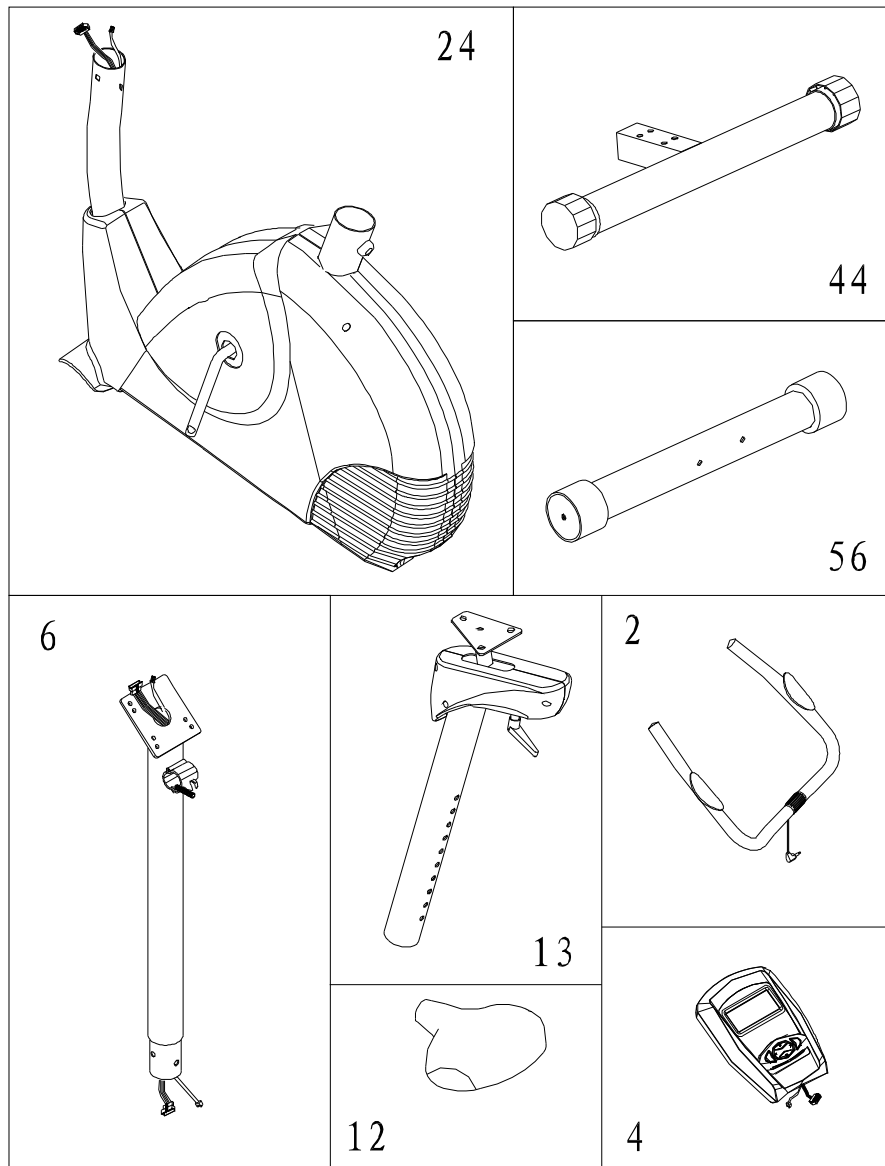

NO.	DESCRIPTION	QTY
24	Main frame	1
56	Front stabilizer w/ transportation wheels	1
44	Rear stabilizer w/adjustable end caps	1
6	Upright	1
13	Seat post	1
2	Handlebar	1
12	Seat	1
4	Computer	1

HARDWARE PACKING LIST

No.	Description	Q'ty	Drawing	
19	Allen head bolt M8x72mm	2		
80	Washer M8	3		
8	Spring washer M8	3		
81	Nylon nut M8	3		
9	Allen head bolt M8x15mm	3		
46	Allen head bolt M8x60mm	4		
35L	Left pedal	1		
35R	Right pedal	1		
52	Seat post adjusting knob	1		
7	L type quick release knob	1		
3	Spacer $\phi 13 \times \phi 8.4 \times 12.5 \text{mm}$	1		
34R	Right pedal strap	1		
34L	Left pedal strap	1		
65	Clamp cover	1		
82	Allen wrench	1		
83	Universal wrench	1		

ASSEMBLY INSTRUCTION

This manual is designed to help you easily assemble, adjust and use this machine. Please read this manual carefully. For the sake of familiarizing yourself with the parts identified in the instruction, first study the overview drawing. Set all parts in a clear area on the floor and remove the packing material. Refer to the parts list for help to identify the parts. It will take two people to assemble your unit.

STEP 1

1. Slide the rear stabilizer (44) with two adjustable end caps (43) into the main frame (24). Secure using four allen head bolts (46).
2. Attach the front stabilizer (56) with two transportation wheels (21) to the curved bracket of main frame (24). Secure using two allen head bolts (19).

NOTE: Make sure you fasten the bolts securely to avoid shaking and discomfort when cycling.

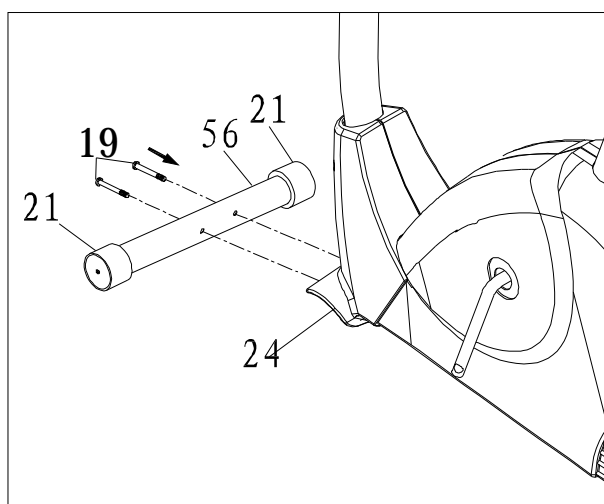
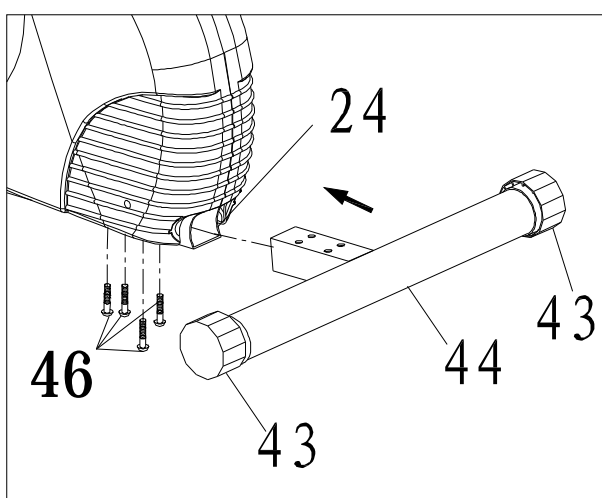

STEP 2

1. Attach the seat (12) to the seat bracket of the seat post (13). Secure using the three washers (80) and three nuts (81) which are pre-assemble on the seat.

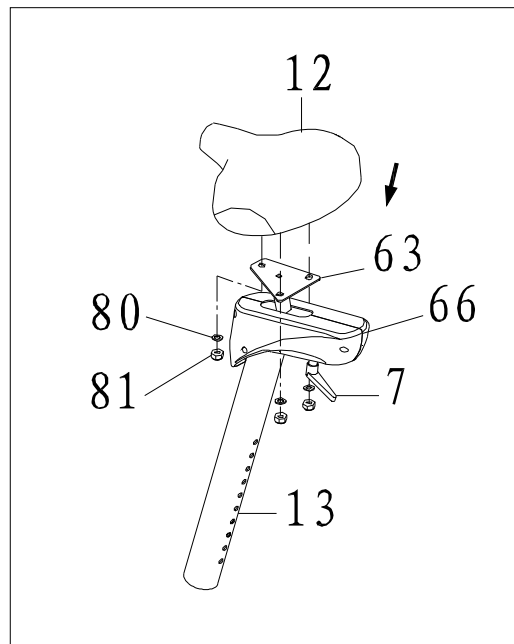

STEP 3

1. Insert the seat post (13) into the main frame (24). Secure in your desired position using the seat post adjusting knob (52).

NOTE: The seat post has 9 adjustable holes to adjust to your desired position.

The seat can be moved back and forth in your desired position. Turn the “L type” quick release button (7) in a counter-clockwise direction to loosen the button and clockwise to tighten the button in your desired position.

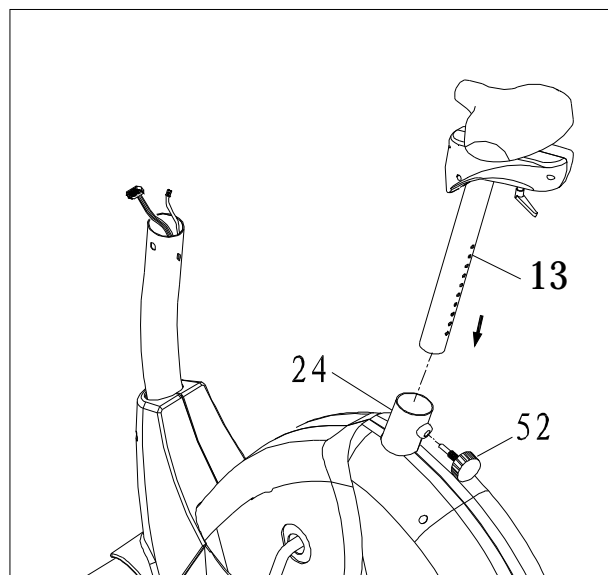

STEP 4

1. Connect the extension motor cable (11) to cable of the motor (22).
2. Connect the extension sensor wire (72) to sensor w/wire (23)
3. Attach the handlebar post (6) into the main frame (24). Secure using three allen head bolt bolts (9) and three spring washers (8) onto the three side of handlebar post (6).

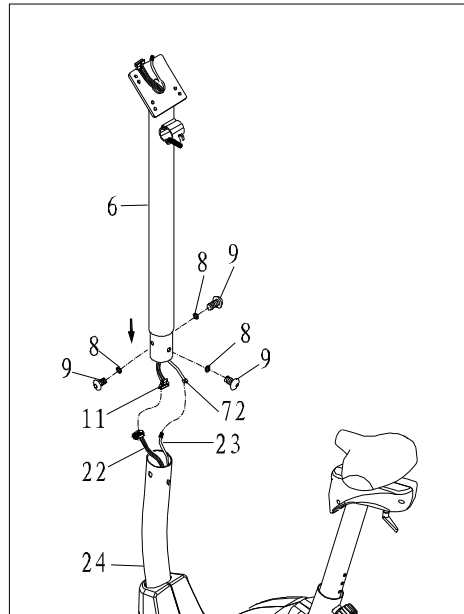

STEP 5

1. Remove the four flat cross head screws (70) from the back of the computer (4).
2. Connect the extension motor cable (11) to the cable form the back of the computer (4).
3. Connect the extension sensor wire (72) to wire at the back of the computer (4).
4. Attach the computer (4) to computer bracket of the handlebar post (6). Secure using four flat cross head screws (70).

NOTE: To avoid pinching the wires, insert the wires into the opening at the top of the handlebar post.

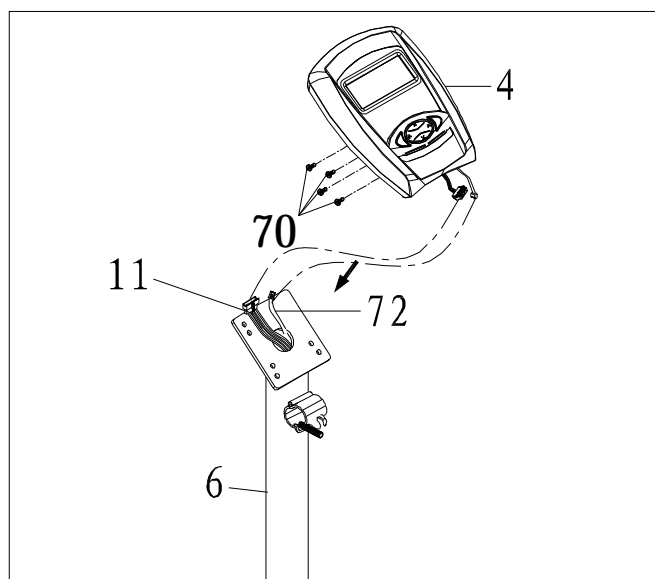

STEP 6

1. Attach the handlebar (2) to the welded clamp of handlebar post (6). Secure using one spacer (3), one clamp cover (65) and "L type" quick release knob (7).
2. Connect the hand pulse wire (14) to the back of the computer (4).

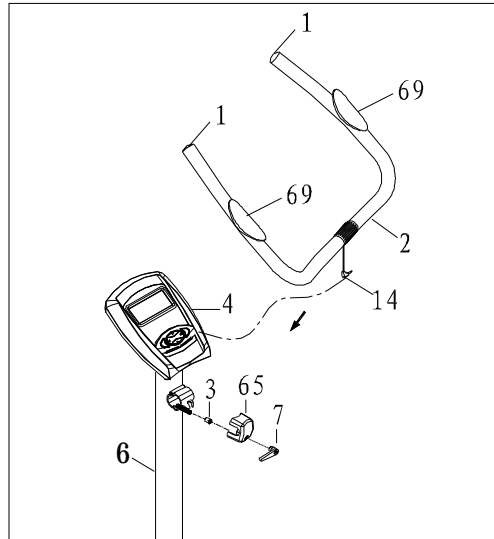

STEP 7

1. Attach the right and left pedal straps (34 R/L) to the right and left pedals (35R/L).
NOTE: The end with four adjustable holes must be set outwards.
2. Attach the right and left pedal (35R/L) to the right and left crank arms (55).
Note: The pedals and crank arms are marked with R & L. The right pedal (R) should be threaded on clockwise and the left pedal (L) should be threaded counter-clockwise

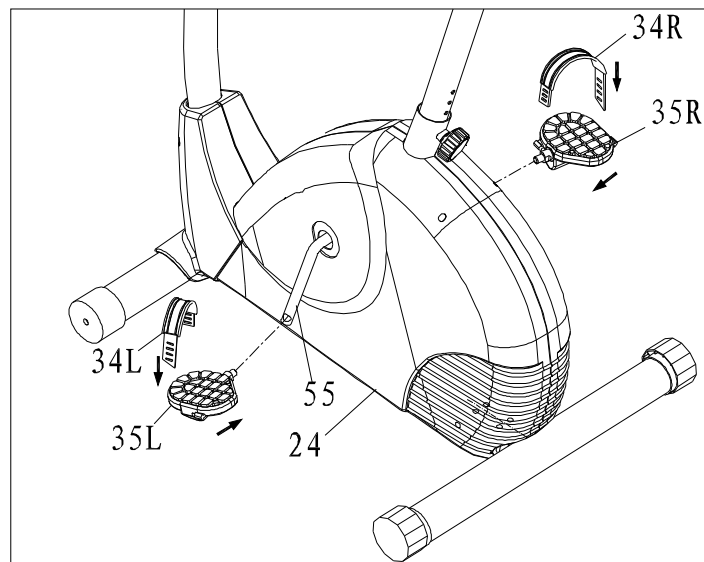

**ENSURE TO FIRMLY TIGHTEN ALL NUTS AND BOLTS
YOUR UNIT IS NOW FULLY ASSEMBLED**

COMPUTER INSTRUCTIONS

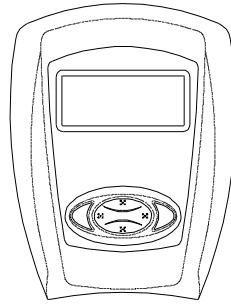

BUTTONS:

▲(UP): Press to select programs P1 to P10. Press to increase the values of the setting mode.
Press to increase the level of the workload when running a program.

▼(DOWN): Press to select programs P1 to P10. Press to decrease the values of the setting mode.
Press to decrease the level of the workload when running a program.

SET: Press to confirm the selected programs P1 to P10. Press the **SET** button to select the values of the various settings.

START/STOP: Press to start the selected program. Press the **START / STOP** button to stop the program. You can press the **START / STOP** button again to continue to run the current program, or use “▲ / ▼” buttons to select a new program.

MODE: Press to select the function value displays of **RPM** and **WATT**, or **SPEED** and **CALORIES**.

RESET: Press to reset all of the function values to zero.

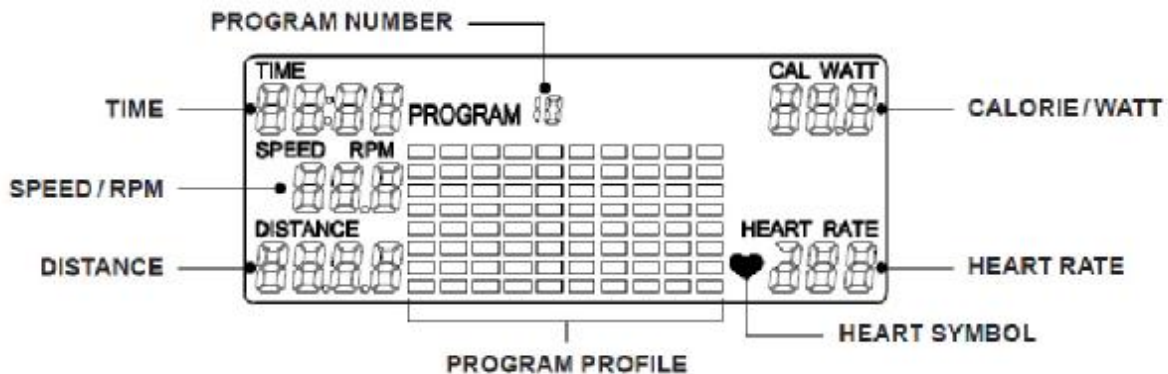

LCD DISPLAY INSTRUCTIONS

- PROGRAM:** Display programs for selection during setup, from P1 to P10. Displays the selected program during exercise.
- TIME:** Displays the time. Counts upward from one second to 99:59 minutes. Counts down from preset value.
- SPEED/RPM:** Displays the current speed from zero 99.9 miles per hour, or RPM from zero to 999 RPM.
Press the **MODE** button to select the display of SPEED or RPM.
- DISTANCE:** Displays the distance from zero to 999.9 miles.
- CALORIE/WATT:** Displays the calorie consumption from zero to 999.9 WATT.
Press the MODE button to select the display of CAL or WATT.
NOTE: The calories and watt readouts are an estimate for an average user. It should be used only as a comparison between workouts on this unit.
- HEART RATE:** Displays heart rate in beats per minute from 40 to 240 beats per minute. To display the heart rate, you must grasp the Pulse sensors on both sides of the handrail, one in each hand. The heart symbol “♥” will begin flashing when the computer senses your hear rate. Your heart rate will be displayed approximately five (5) seconds after the heart icon is displayed. If you do not place your hands correctly and 60 seconds passes without a heart rate reading, the computer will turn off the heart rate circuit. If this occurs, press the **MODE** button to restart the heart rate circuit, place your hands back on the Pulse Sensors correctly, and the heart rate readout will appear.

PROGRAM DESCRIPTIONS

This computer contains 10 different programs. You can preset the program time and the computer will divide the time chosen into 10 intervals. If you do not set the programs time in advance, the computer will default to a 30 minute workout time.

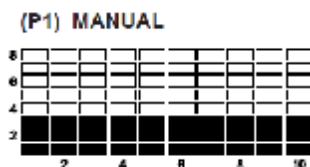

MANUAL PROGRAM:

P1 is a manual program allowing the user to full manual control of the workload. Use the “▲” button to increase load. Use the “▼” button to decrease the load.

PRESET PROGRAMS: P2 to P10 are preset automatic programs. The profiles are shown on the face of the computer. Use the “▲” button to increase the load level of the program. Use the “▼” button to decrease the load level of the program.

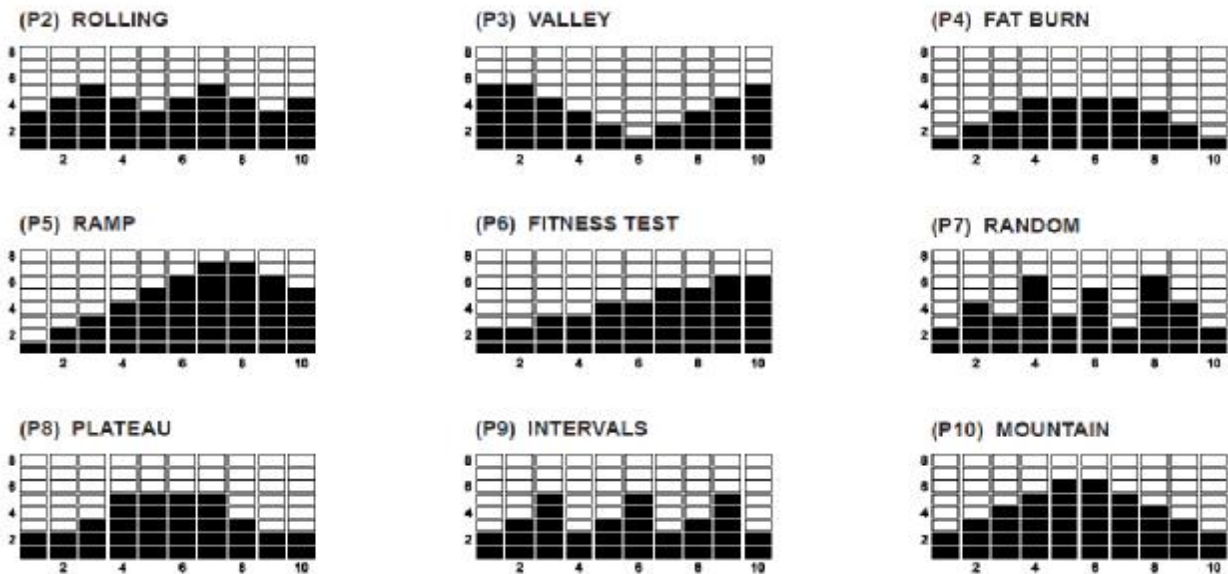

COMPUTER OPERATION

STEP 1: POWER ON

Pedaling or press any button.

STEP 2: SELECT PROGRAM

Press the “▲ / ▼” buttons until the desired program is displayed.

STEP 3: SET THE PROGRAM TIME

Press the **SET** button, the **TIME** function mode will appear with the display flashing “0:00”. Press the SET button again to pass setting the program time. Or use the “▲ / ▼” buttons to set the program time, from 5 minutes up to 99 minutes with one minute increments. Press the SET button to confirm the setting. Press the **START/STOP** button to start the program.

NOTE:

1. The program will not start until you press the START / STOP button
2. If you don't set the program time, the computer will count up from one second up to 99:59 Minutes, and use the default workout time, 30 minutes, to cycle run the program profile.
3. The computer will count down from the program time that you set. When the timer counts down to zero, the computer will alert you with an audible alarm that your workout is complete. You can press any button to stop the audible alarm.

OPERATION DESCRIPTIONS

1. Monitor requires four “AA” batteries.
2. To stop a running program, press the **START / STOP** button. In this mode, you can press the **START / STOP** button again to continue to run the current program. Or, you can use the “▲ / ▼” buttons to select a new program. The function values of **DISTANCE** and **CALORIE** will continue to accumulate.
3. When you complete a program, press the **START / STOP** button to stop the program. You can use the “▲ / ▼” buttons to select a new program. The function values of **DISTANCE** and **CALORIE** will continue to accumulate. This will allow you to run several programs and still know the total **DISTANCE** and **CALORIE** during the workout.
4. If you want to restart with a new program, press the **RESET** button to reset all of the function values to zero. Use the “▲ / ▼” buttons to select a new program.
5. The computer will shut off automatically after 4 minutes of inactivity, and the function values, **DISTANCE** and **CALORIE**, will be kept.

DIAGRAM

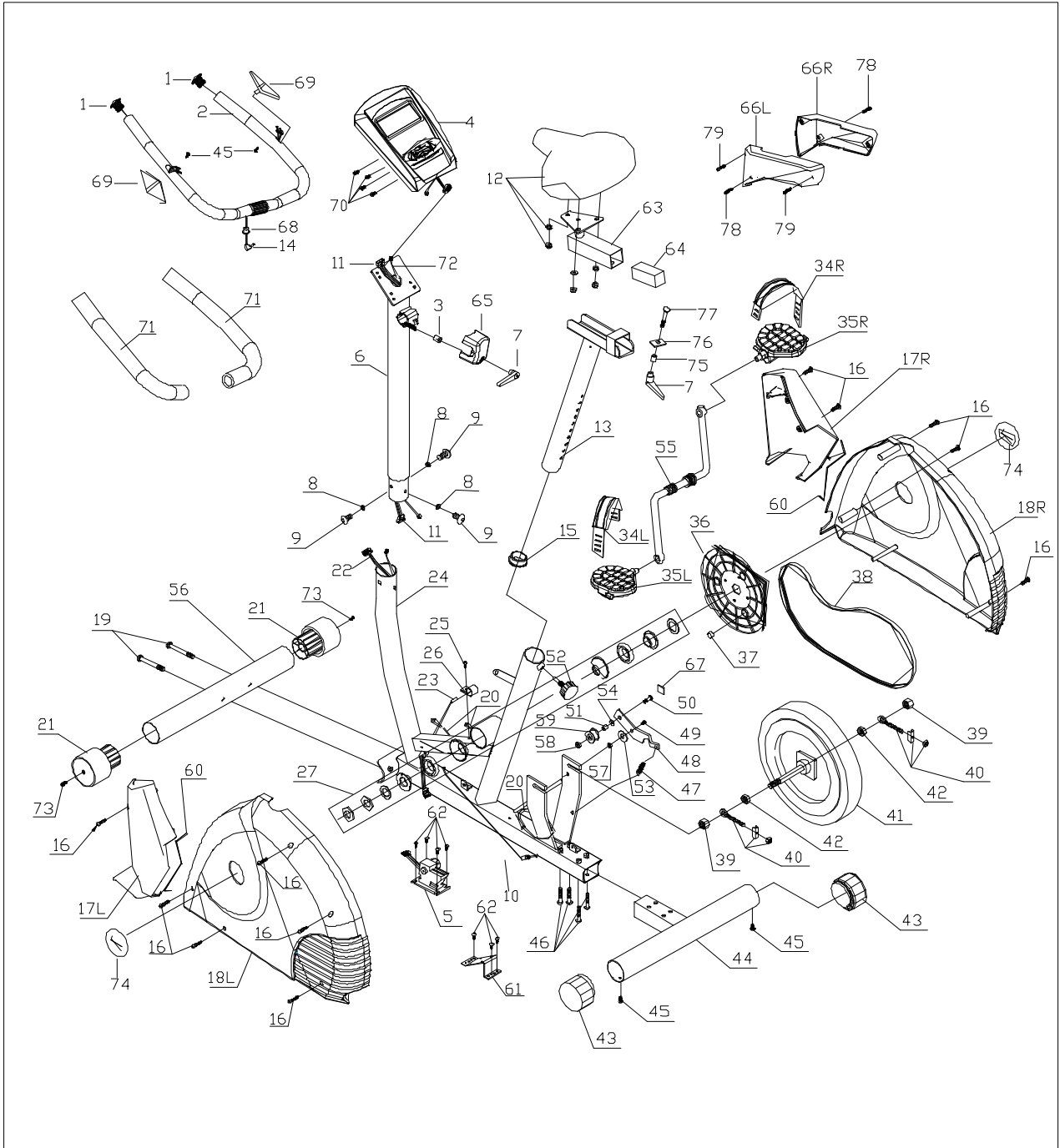

PARTS LIST

KEY NO.	PART NO.	DESCRIPTION	QTY
1	62601	End cap	2
2	62602	Handlebar	1
3	62603	Spacer ϕ 13X ϕ 8.4X12.5L	1
4	62604	Computer	1
5	62605	Motor w/cable	1
6	62606	Handlebar post	1
7	62607	L type quick release knob	2
8	62608	Spring washer M8	3
9	62609	Allen head bolt M8x1.25Px15L	3
10	62610	Resistant cable	1
11	62611	Extension motor cable	1
12	62612	Seat	1
13	62613	Seat post	1
14	62614	Handpulse wire	1
15	62615	Seat post bushing	1
16	62616	Screw M4x25L	11
17R	62617R	Front cover right	1
17L	62617L	Front cover left	1
18R	62618R	Chain guard right	1
18L	62618L	Chain guard left	1
19	62619	Allen had bolt M8X72L	2
20	62620	Tiny band	3
21	62621	Transportation wheel	2
22	62622	Motor w/cable	1
23	62623	Sensor w/wire	1
24	62624	Main frame	1
25	62625	Screw M5x15	1
26	62626	Sensor holder	1
27	62627	Bearing assembly	1
34R	62634R	Pedal strap right	1
34L	62634L	Pedal strap left	1
35R	62635R	Pedal right	1

KEY NO.	PART NO.	DESCRIPTION	QTY
35L	62635L	Pedal left	1
36	62636	Belt pulley ϕ 240	1
37	62637	Magnet ϕ 15x6.5H	1
38	62638	Drive belt 370 J6	1
39	62639	Nut 3/8"x26Wx7H	2
40	62640	Belt adjuster (3 in 1)	2
41	62641	Mag. flywheel system w/pivot shaft	1
42	62642	Nut 3/8"x26Wx4H	2
43	62643	Adjustable end cap	2
44	62644	Rear stabilizer	1
45	62645	Screw M4X15L	4
46	62646	Allen head bolt M8X60L	4
47	62647	Spring ϕ 17x ϕ 2.3X75L	1
48	62648	Idler wheel bracket	1
49	62649	Flat allen head screw M8x1.25px20L	1
50	62650	Flat allen head screw M10x1.5px33L	1
51	62651	Spacer ϕ 15x ϕ 10x8H	1
52	62652	Seat post adjusting knob	1
53	62653	Flat washer ϕ 32x ϕ 16.5x0.5t	1
54	62654	Flat washer ϕ 20x ϕ 10.5x1.0t	1
55	62655	Crank 6"	1
56	62656	Front stabilizer	1
57	62657	Nylon Nut M8X6H	1
58	62658	Nylon Nut M10X7H	1
59	62659	Idler wheel	1
60	62660	Sticker	2
61	62661	Motor fix bracket	1
62	62662	Flat head screw M5X12L	7
63	62663	Seat bracket with slider	1
64	62664	Slider foam stopper 30x35x80L	1
65	62665	Clamp cover	1
66R	62666R	Seat slider cover right	1
66L	62666L	Seat slider cover left	1

KEY NO.	PART NO.	DESCRIPTION	QTY
67	62667	Foam pad	1
68	62668	Handpulse plug	1
69	62669	Handpulse sensor	2
70	62670	Flat cross head screw M5X15L	4
71	62671	Foam grip	2
72	62672	Extension sensor wire	1
73	62673	Screw M4X12L	2
74	62674	Crank cover	2
75	62675	Spacer $\Phi 15 \times \phi 8.4 \times 15h$	1
76	62676	Seat slider bracket	1
77	62677	Carriage bolt M8x1.25Px35L	1
78	62678	Round head screw M5x15L	2
79	62679	Round head screw M4x15L	2
80	62680	Washer	3
81	62681	Nut	3
82	62682	Allen wrench	1
83	62683	Universal wrench	1

TROUBLE SHOOTING

Problem	Cause	Correction
Monitor does not display	Batteries not installed	Insert batteries
No speed or distance displays on the monitor	Sending unit not connected	Securely plug sending unit into extension wire and the back of the computer
	Sending unit not working properly	Replace sending unit
	Computer not working properly	Replace computer
No tension	Motor cable or resistant cable not connected	Securely connect the motor cable into the extension motor cable and the resistant cable
	Magnetic wheel not working properly	Replace magnetic wheel
Heart rate not displaying	Pulse wire not connected not connected	Securely plug wires together
	Hand pulse defective	Replace hand pulse
	Computer not working properly	Replace computer
Grinding	Crank bearing defective	Replace crank bearings
	Idler pulley defective	Replace idler pulley
	Mag. flywheel defective	Replace mag. flywheel
Squealing	Poly V-belt slipping	Adjust poly v-belt

TRAINING GUIDELINES

Exercise

Exercise is one of the most important factors in the overall health of an individual. Listed among its benefits are:

- Increased capacity for physical work (strength endurance)
- Increased cardiovascular (heart and arteries/veins) and respiratory efficiency
- Decreased risk of coronary heart disease
- Changes in body metabolism, e.g. losing weight
- Delaying the physiological effects of age
- Physiological effects, e.g. reduction in stress, increase in self-confidence, etc.

Basic Components of Physical Fitness

There are four all encompassing components of physical fitness and we need to briefly define each and clarify its role.

Strength is the capacity of a muscle to exert a force against resistance. Strength contributes to power and speed and is of great importance to a majority of sports people.

Muscular Endurance is the capacity to exert a force repeatedly over a period of time, e.g. it is the capacity of your legs to carry you 10 Km without stopping.

Flexibility is the range of motion about a joint. Improving flexibility involves the stretching of muscles and tendons to maintain or increase suppleness, and provides increased resistance to muscle injury or soreness.

Cardio-Respiratory Endurance is the most essential component of physical fitness. It is the efficient functioning of the heart and lungs

Aerobic Fitness

The largest amount of oxygen that you can use per minute during exercise is called your maximum oxygen uptake (MVo₂). This is often referred to as your aerobic capacity.

The effort that you can exert over a prolonged period of time is limited by your ability to deliver oxygen to the working muscles. Regular vigorous exercise produces a training effect that can increase your aerobic capacity by as much as 20 to 30%. An increased MVO₂ indicates an increased ability of the heart to pump blood, of the lungs to ventilate oxygen and of the muscles to take up oxygen.

Anaerobic Training

This means “without oxygen” and is the output of energy when the oxygen supply is insufficient to meet the body’s long term energy demands. (For example, 100 meter sprint).

The Training Threshold

This is the minimum level of exercise which is required to produce significant improvements in any physical fitness parameter.

Progression

As you become fitter, a higher intensity of exercise is required to create an overload and therefore provide continued improvement

Overload

This is where you exercise at a level above that which can be carried out comfortably. The intensity, duration and frequency of exercise should be above the training threshold and should be gradually increased as the body adapts to the increasing demands. As your fitness level improves, so the training threshold should be raised. Working through your program and gradually increasing the overload factor is important.

Specificity

Different forms of exercise produce different results. The type of exercise that is carried out is specific both to the muscle groups being used and to the energy source involved. There is little transfer of the effects of exercise, i.e. from strength training to cardiovascular fitness. That is why it is important to have an exercise program tailored to your specific needs.

Reversibility

If you stop exercising or do not do your program often enough, you will lose the benefits you have gained. Regular workouts are the key to success.

Warm Up

Every exercise program should start with a warm up where the body is prepared for the effort to come.

It should be gentle and preferably use the muscles to be involved later. Stretching should be included in both your warm up and cool down, and should be performed after 3-5 minutes of low intensity aerobic activity or callisthenic type exercise.

Warm Down or Cool Down

This involves a gradual decrease in the intensity of the exercise session. Following exercise, a large supply of blood remains in the working muscles. If it is not returned promptly to the central circulation, pooling of blood may occur in the muscles

Heart Rate

As you exercise, so the rate at which your heart beat also increases. This is often used as a measure of the required intensity of exercise. You need to exercise hard enough to condition your circulatory system, and increase your pulse rate, but not enough to strain your heart.

Your initial level of fitness is important in developing an exercise program for you. If you are starting off, you can get a good training effect with a heart rate of 110-120 beats per minute (BPM). If you are fitter, you will need a higher threshold of stimulation.

To begin with, you should exercise at a level that elevates your heart rate to about 65 to 70% of your maximum. If you find this is too easy, you may want to increase it, but it is better to lean on the conservative side.

As a rule of thumb, the maximum heart rate is 220 minus your age. As you increase in age, so your heart, like other muscles, loses some of its efficiency. Some of its natural loss is won back as fitness improves. The following table is a guide to those who are "starting fitness".

Age	25	30	35	40	45	50	55	60	65
Target heart Rate									
10 Second Count	23	22	22	21	20	19	19	18	18
Beats per Minute	138	132	132	126	120	114	114	108	108

Pulse Count

The pulse count(on your wrist or carotid artery in the neck, taken with two index fingers)is done for ten seconds, taken a few seconds after you stop exercising. This is for two reasons: (a) 10 seconds is long enough for accuracy, (b) the pulse count is to approximate your BPM rate at the time you are exercising. Since heart rate slows as you recover, a longer count isn't as accurate.

The target is not a magic number, but a general guide. If you're above average fitness, you may work quite comfortably a little above that suggested for your age group. The following table is a guide to those who are keeping fit. Here we are working at about 80% of maximum.

Age	25	30	35	40	45	50	55	60	65
Target heart Rate									
10 Second Count	26	26	25	24	23	22	22	21	20
Beats per Minute	156	156	150	144	138	132	132	126	120

Don't push yourself too hard to reach the figures on this table. It can be very uncomfortable if you overdo it. Let it happen naturally as you work through your program. Remember, the target is a guide, not a rule, a little above or below is just fine. Two final comments: (1) don't be concerned with day to day variations in your pulse rate, being under pressure or not enough sleep can affect it;(2) your pulse rate is a guide, don't become a slave to it.

Endurance Circuit Training

Cardiovascular endurance, muscle, strength, flexibility and coordination are all necessary for maximum fitness. The principle behind circuit training is to give a person all the essentials at one time by going through your exercise program moving as fast as possible between each exercise. This increases the heart rate and sustains it, which improves the fitness level. Do not introduce this circuit training effect until you have reached an advanced program stage.

Body Building

Is often used synonymously with strength training The fundamental principal here is OVERLOAD. Here, the muscle works against greater loads than usual. This can be done by increasing the load you are working against.

Patronization

This is the term used to vary your exercise program for both physiological and psychological benefits. In your overall program, you should vary the workload, frequency and intensity. The body responds better to variety and so do you. In addition, when you feel yourself getting "stale", bring in periods of lighter exercise to allow the body to recuperate and restore its reserves. You will enjoy your program more and feel better for it.

Muscle Soreness

For the first week or so, this may be the only indication you have that you are on an exercise program. This, of course, does depend on your overall fitness level. A confirmation that you are on the correct program is a very slight soreness in most major muscle groups. This is quite normal and will disappear in a matter of days. If you experience major discomfort, you may be on a program that is too advanced or you have increased your program too rapidly. If you experience PAIN during or after exercise, your body is telling you something. Stop exercising and consult your doctor.

What to Wear

Wear clothing that will not restrict your movement in any way while exercising. Clothes should be light enough to allow the body to cool. Excessive clothing that causes you to perspire more than you normally would while exercising, gives you no advantage. The extra weight you lose is body fluid and will be replaced with the next glass of water you drink. It is advisable to wear a pair of gym or running shoes or "sneakers".

Breathing during Exercise

Do not hold your breath while exercising. Breathe normally as much as possible. Remember, breathing involves the intake and distribution of oxygen, which feeds the working muscles.

Rest periods

Once you start your exercise program, you should continue through to the end. Do not break off halfway through and then restart at the same place later on without going through the warm-up stage again. The rest period required between strength training exercises may vary from person to person. This will depend mostly on your level of fitness and the program you have chosen. Rest between exercises by all means, but do not allow this to exceed two minutes. Most people manage with half minute to one minute rest periods.

STRETCHING

Stretching should be included in both your warm up and cool down, and should be performed after 3-5 minutes of low intensity aerobic activity or callisthenic type exercise. Movements should be performed slowly and smoothly, with no bouncing or jerking. Move into the stretch until slight tension, not pain, is felt in the muscle and hold for 20-30 seconds. Breathing should be slow, rhythmical and under control, making sure never to hold your breath.

HEAD ROLLS

Rotate your head to the right for one count, feeling the stretch up the left side of your neck. Next rotate your head back for one count, stretching your chin to the ceiling and letting your mouth open. Rotate your head to the left for one count, and finally, drop your head to your chest for one count.

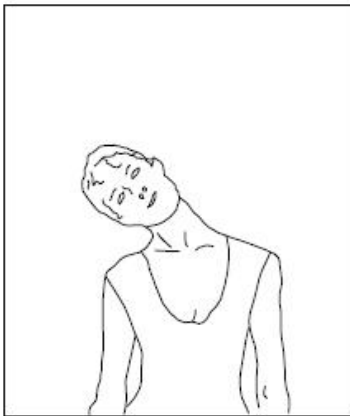

SHOULDER LIFTS

Lift your right shoulder up toward your ear for one count. Then lift your left shoulder up for one count as you lower your right shoulder.

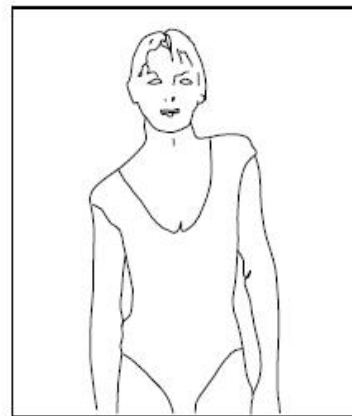

SIDE STRETCHES

Open your arms to the side and continue lifting them until they are over your head. Reach your right arm as far upward toward the ceiling as you can for one count. Feel the stretch up your right side. Repeat this action with your left arm.

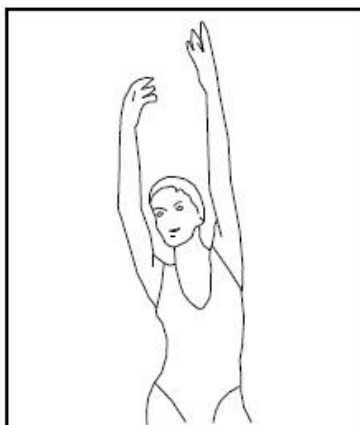

QUADRICEPS STRETCH

With one hand against a wall for balance, reach behind you and pull your right foot up. Bring your heel as close to your buttocks as possible. Hold for 15 counts and repeat with left foot up.

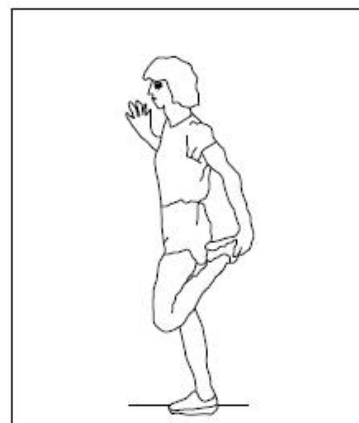

INNER THIGH STRETCH

Sit with the soles of your feet together with your knees pointing outward. Pull your feet as close into your groin as possible. Gently push your knees towards the floor. Hold for 15 counts.



TOE TOUCHES

Slowly bend forward from your waist, letting your back and shoulders relax as you stretch toward your toes. Reach down as far as you can and hold for 15 counts.

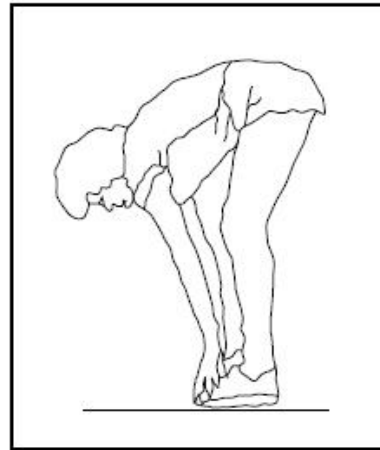

HAMSTRING STRETCHES

Sit with your right leg extended. Rest the sole of your left foot against your right inner thigh. Stretch toward your toe as far as possible. Hold for 15 counts. Relax and then repeat with left leg extended.

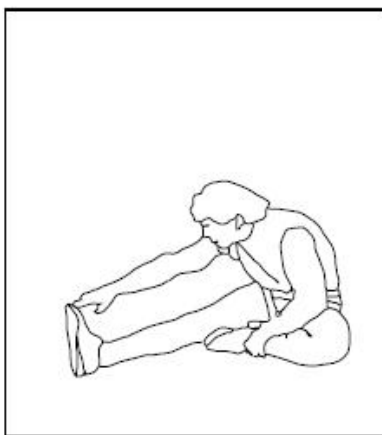

CALF / ACHILLES STRETCH

Lean against a wall with your left leg in front of the right and your arms forward. Keep Your right leg straight and the left foot on the floor, then bend the left leg and lean forward by moving your hips toward the wall. Hold, then repeat on the other side for 15 counts.

