

OWNER'S MANUAL

Model No.
16516632-1

- *Assembly*
- *Operation*
- *Exercise*
- *Parts*
- *Warranty*

CAUTION:

You must read and understand this owner's manual before operating unit.



Indoor Cycle Trainer

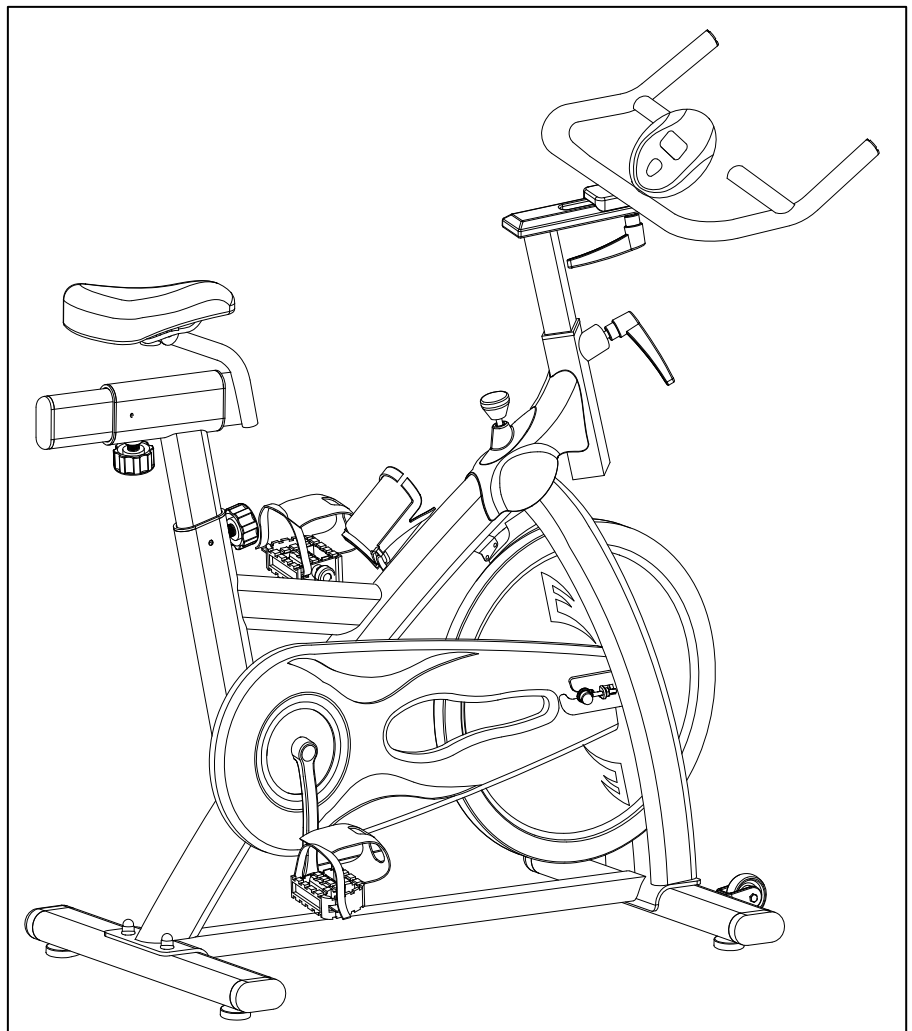

RETAIN FOR FUTURE REFERENCE

MAURICE PINCOFFS CANADA INC. 6050 DON MURIE STREET, NIAGARA FALLS, ONTARIO L2E X8

Manufacture's One-Year Limited Warranty

Your **Everlast** Indoor Cycle Trainer is warranted for one year from the date of purchase against defects in material when used for the purpose intended, under normal conditions and provided it receives proper care. Any part found defective or missing will be sent at no cost when returned in accordance with the terms of this warranty.

This warranty is not transferable and is extended only to the original owner.

The warranty shall not apply to exercise units which are (1) used for commercial or other income producing purposes, or (2) subject to misuse, neglect, accident or unauthorized repair and alterations.

This warranty provided herein is lieu of all other express warranties, any implied warranties, including any implied warranties of merchantability of fitness for particular purpose, are limited in duration to the first 12 months from date of purchase. All other obligations or liabilities, including liability for consequential damages are hereby excluded.

REPAIR PARTS AND SERVICE

All of the parts for the rowing machine, shown in figure can be ordered from Maurice Pincoffs Canada Inc. 6050 DON MURIE STREET, NIAGARA FALLS, ONTARIO L2E 6X8. When ordering parts, the parts will be sent and billed at the current prices. Prices may be subject to change without notice. Check or money order must accompany all orders. Standard hardware items are available at your local hardware store.

To ensure prompt and correct handling of any errors, or to answer any questions, please call our Toll Free number: 1-888-707-1880, or local number 1-905-353-8955 or fax 1-905-353-8968 or email customerservice@pincoffs.ca or visit us at: www.pincoffs.ca. Office hours are from 8:30 AM to 5:00 PM Monday to Friday Eastern Standard Time.

Always include the following information when ordering parts

- Model number
- Name of each part
- Part number of each part

TABLE OF CONTENTS

WARRANTY	2	DIAGRAM	11
SAFETY PRECAUTIONS	3	COMPUTER INSTRUCTION	12
PRE-ASSEMBLY CHECK LIST	4	TROUBLE SHOOTING	13
HARDWARE PACKING LIST	5	BRAKE PADS REPLACEMENT	14
ASSEMBLY INSTRUCTION	6-8	TRAINING GUIDELINES	15-17
PARTS LIST	9-10	EXERCISE	18-19

SAFETY PRECAUTIONS

Thank you for purchasing our product. Even though we go to great efforts to ensure the quality of each product we produce, occasional errors and/or omissions do occur. In any event should you find this product to have either a defective or a missing part please contact us for a replacement.

This product has been designed for home use only. Product liability and guarantee conditions will not be applicable to products being subjected to professional use or products being used in a gym centre.

This exercise equipment was designed and built for optimum safety. However, certain precautions apply whenever you operate a piece of exercise equipment. Be sure to read the entire manual before assembly and operation of this machine. Also, please note the following safety precautions:

1. Read the OWNER'S OPERATING MANUAL and all accompanying literature and follow it carefully before using your Indoor Cycle Trainer.
2. If dizziness, nausea, chest pains, or any other abnormal symptoms are experienced while using this equipment, STOP the workout at once. CONSULT A PHYSICIAN IMMEDIATELY.
3. Inspect your exercise equipment prior to exercising to ensure that all nuts and bolts are fully tightened before each use.
4. The Cycle Trainer must be regularly checked for signs of wear and damage. Any part found defective, the part must be replaced with new spare part from the manufacturer.
5. Fitness equipment must always be installed on a flat surface, do not place the unit on a loose rug or uneven surface. It is recommended to use an equipment mat to prevent the unit from moving while it is being used, which could possibly scratch or damage the surface of your floor.
6. No changes must be made which might compromise the safety of the equipment.
7. It is recommended to have a minimum of 2' safe clearance around the exercise equipment while in use.
8. Keep children and pets away from this equipment at all times while exercising.
9. Warm up 5 to 10 minutes before each workout and cool down 5 to 10 minutes afterward. This allows your heart rate to gradually increase and decrease and will help prevent you from straining muscles.
10. Never hold your breath while exercising. Breathing should remain at a normal rate in conjunction with the level of exercise being performed
11. Always wear suitable clothing and footwear while exercising. Do not wear loose fitting clothing that could become entangled with the moving parts of your Indoor Cycle Trainer.
12. Care must be taken when lifting or moving the equipment, so as not to injure your back. Always use proper lifting techniques
13. User weight should not exceed 285 lbs.

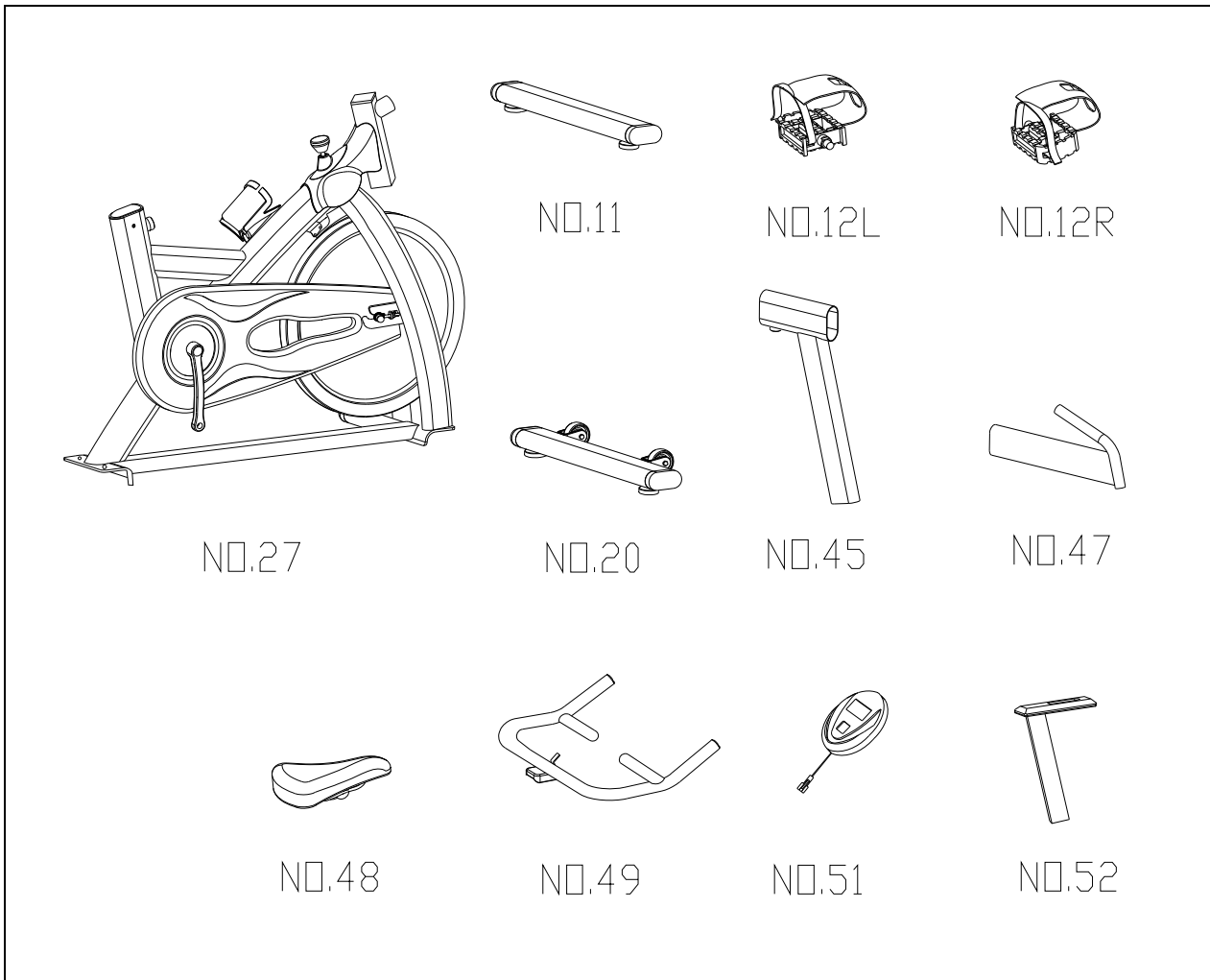

WARNING: Before beginning any exercise program consult your physician. This is especially important for individuals over the age of 35 or persons with pre-existing health problems. Read all instructions before using any fitness equipment. We assume no responsibility form personal injury or property damage sustained by or through the use of this product.

PRE-ASSEMBLY CHECK LIST

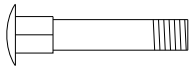
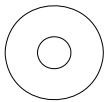
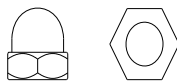

PART NO.	DESCRIPTION	Q'TY
27	Main Frame	1
41	Rear Stabilizer	1
12L	Left Pedal	1
12R	Right Pedal	1
20	Front Stabilizer	1
45	Seat Post	1
47	Sliding Tube	1
48	Seat	1
49	Handlebar	1
51	Computer	1
52	Handlebar Post	1
69	Replacement brake pad	1
	Inner Box	1
	Manual	1

HARDWARE PACKING LIST

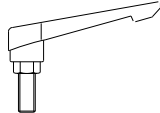
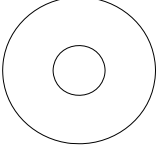
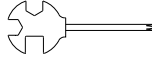
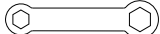
Part NO	Description	Q'ty	Drawings	
22	Carriage Bolt M8*45	4		
25	Flat Washer φ8	4		
26	Domed Nut M8	4		
42	Quick Release Knob	2		
30	L type Knob	2		
53	Flat Washer	1		
	Spanner	1		
	Spanner S13	1		

Above described parts are all the parts you need to assemble this machine. Before you start to assemble, please check the hardware packing to make sure they are included.

ASSEMBLY INSTRUCTION

This manual is designed to help you easily assemble, adjust and use this machine. Please read this manual carefully. For the sake of familiarizing yourself with the parts identified in the instruction, first study the overview drawing.

Set all parts in a clear area on the floor and remove the packing material. Refer to the parts list for help to identify the parts.

It will take two people to assemble your unit.

ENSURE THAT ALL NUTS AND BOLTS ARE FIRMLY TIGHTENED AFTER EACH STEP

STEP 1

1. Attach the front stabilizer (20) to the main frame (27). Secure using two carriage bolts (22), two flat washers (25) and two domed nuts (26).
2. Attach the rear stabilizer assembly (41) to the main frame (27). Secure using two carriage bolts (22), two flat washers (25) and two domed nuts (26).

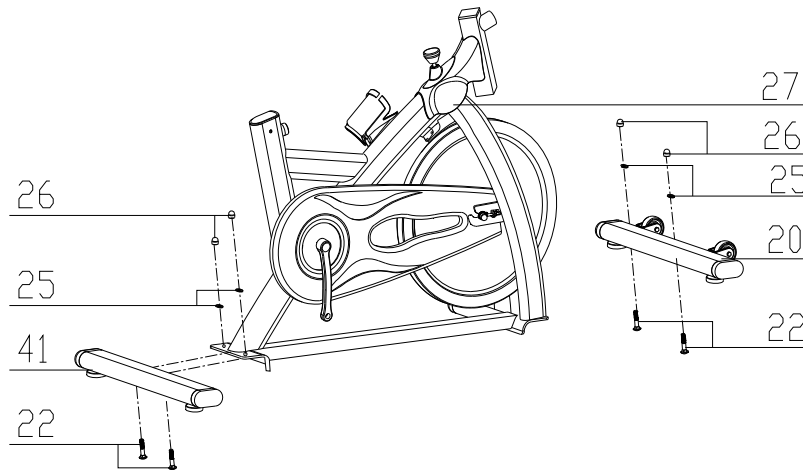

STEP 2

1. Attach the seat (48) to the sliding tube (47).
2. Insert the sliding tube (47) to the seat post (45) at your desired location. Secure using the quick release knob (42).
3. Insert the seat post (45) into the main frame (27) at your desired location. Secure using the quick release knob (42).

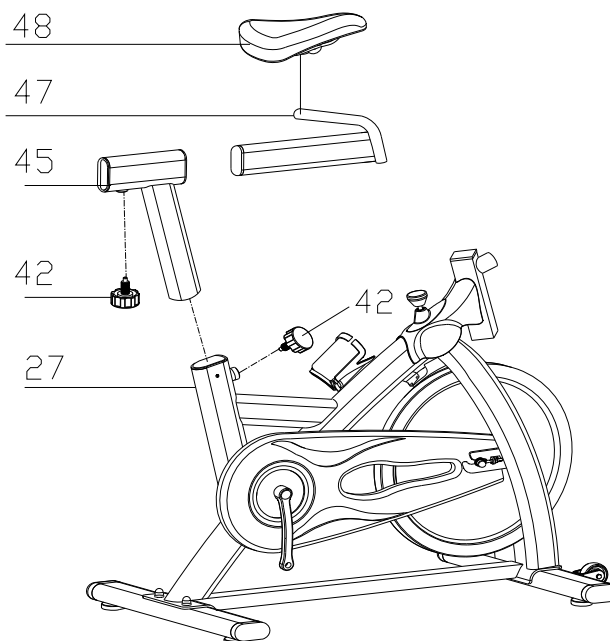

STEP 3

1. Insert the handlebar post (52) into the main frame (27). Secure using the L lock knob (30).
2. Attach the handlebar (49) to the handlebar post (52). Secure using a flat washer (53) and L lock knob (30).
3. Insert the computer (51) onto the bracket of the handlebar (49).
4. Connect the sensor wire (57) to the wire at the back of the computer. See inset.

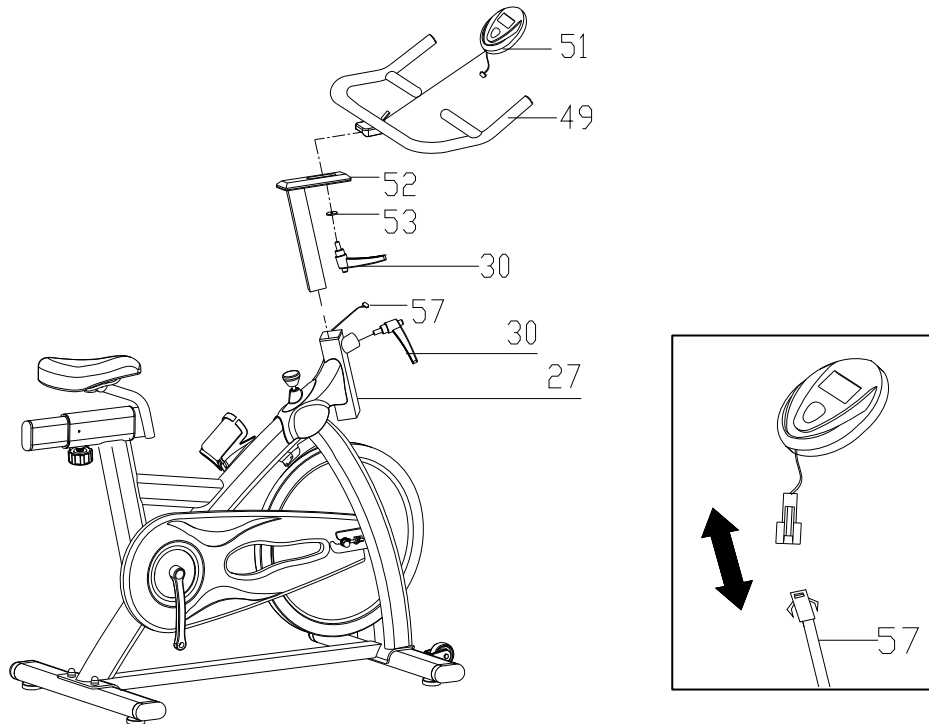

STEP 4

Attach the left pedal (12L) to the left crank arm (33).

Attach the right pedal (12R) to the right crank (13).

Note: the right pedal should be threaded on clockwise and the left pedal on counter-clockwise.

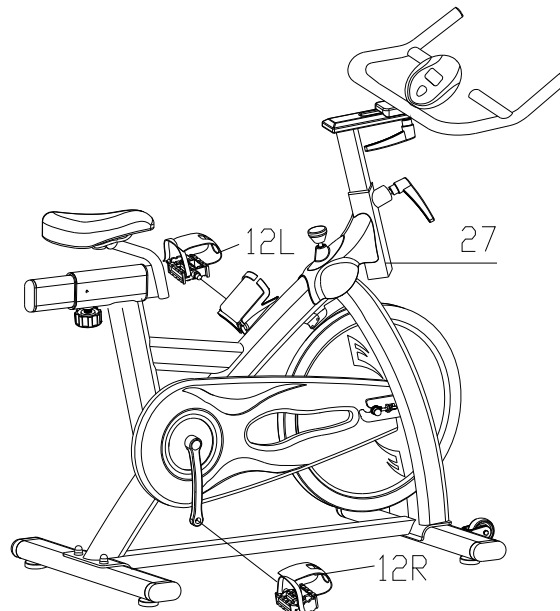

YOUR UNIT IS NOW FULLY ASSEMBLED

Adjusting the tension

1. Turn the tension/brake knob (58) clockwise to increase the tension.
2. Turn the tension/brake knob (58) counter-clockwise to decrease the tension.

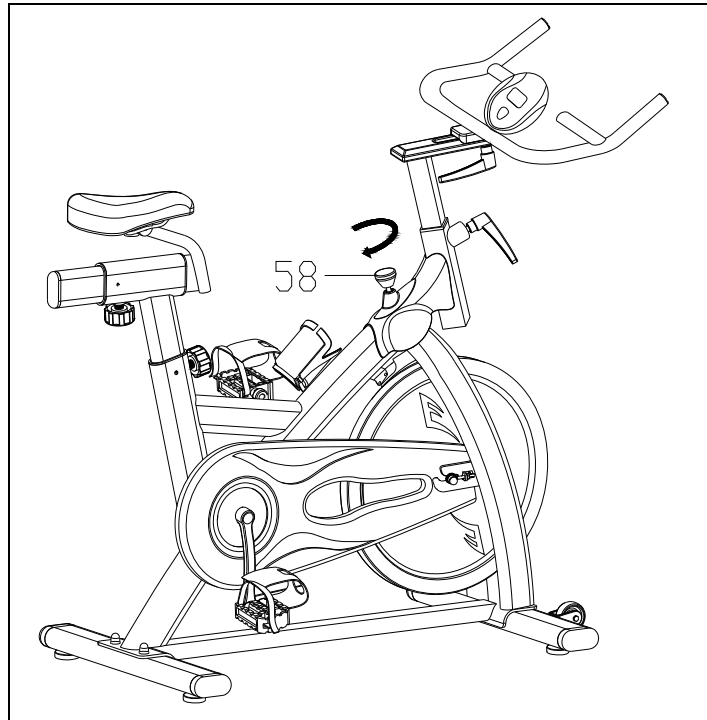

IMPORTANT: Press down on the tension/brake knob (58) to stop the flywheel.

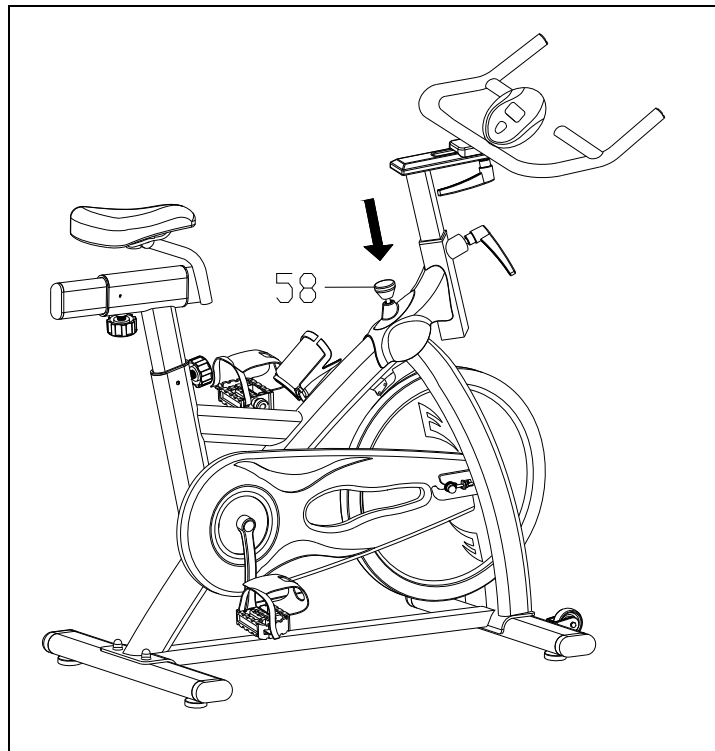

Note: If the unit is wobbly use the leveling pads on the front and rear stabilizers to level the unit

PARTS LIST

No.	Part No.	Description	Qty
1	1663201	Hex head nut M10	3
2	1663202	Axle for Flywheel	1
3	1663203	Spacer for Flywheel	1
4	1663204	Bearing 6000ZZ	2
5	1663205	Flywheel	1
6	1663206	Spacer for Flywheel	1
7	1663207	Flywheel Cover	1
8	1663208	Self-tapping screw ST4.2*19	9
9	1663209	Crank End Cap	2
10	1663210	France nut M10	2
11	1663211	Chain Cover	1
12L	1663212L	Left Pedal	1
12R	1663212R	Right Pedal	1
13	1663213	Right Crank	1
14	1663214	Allen bolt M8*15	4
15	1663215	Belt-drive wheel	1
16	1663216	Hex head nut M8	6
17	1663217	End cap for stabilizer	4
18	1663218	Nut M8	4
19	1663219	Tension cover	1
20	1663220	Front stabilizer	1
21	1663221	Leveling pad	4
22	1663222	Carriage bolt M8*55	4
23	1663223	Transportation wheel	2
24	1663224	Hex head bolt M8*40	2
25	1663225	Flat Washer $\phi 8$	4
26	1663226	Domed nut	4
27	1663227	Main frame	1
28	1663228	Washer	1
29	1663229	Fixing nut	1
30	1663230	L lock knob	2
31	1663231	Bearing 6004ZZ	2
32	1663232	Crank cover	1
33	1663233	Left crank	1
34	1663234	Belt	1
35	1663235	Self-tapping screw ST4.2*16	2
36	1663236	Inner chain cover	1
37	1663237	Short spacer	1

PARTS LIST

No.	Part No.	Description	Qty
38	1663238	Long spacer	1
39	1663239	Axle for crank	1
40	1663240	Nut	1
41	1663241	Rear stabilizer	1
42	1663242	Quick release knob	2
43	1663243	Inner end cap	3
44	1663244	Bottle holder	1
45	1663245	Seat post	1
46	1663246	End cap for sliding tube	1
47	1663247	Sliding tube	1
48	1663248	Seat	1
49	1663249-1	Handlebar	1
51	1663251	Computer	1
52	1663252	Handlebar post	1
53	1663253	Flat washer	1
55	1663255	Inner end cap 38*38	1
56	1663256	Inner cap for handlebar post	1
58	1663258	Tension/brake knob	1
59	1663259	Spacer for brake	1
60	1663260	Spring ϕ 1.8	1
61	1663261	Nut for brake	1
62	1663262	Spring ϕ 1.0	1
63	1663263	Long spacer for Flywheel	1
64	1663264	Flat washer	1
65	1663265	Domed nut M6	1
66	1663266	Spring cover	1
67	1663267	Spring ϕ 2.2	1
68	1663268	Brake holder	1
69	1663269	Brake pads	1
70	1663270	Hex head bolt M5*30	2
71	1663271	Adjustable plate	1
72	1663272	Lock nut M5	2
73	1663273	Hex head bolt M5*10	2
74	1663274	France nut M10	2
75	1663275	Fixing bolt M6*48	2
76	1663276	Hex head nut M6	2

DIAGRAM

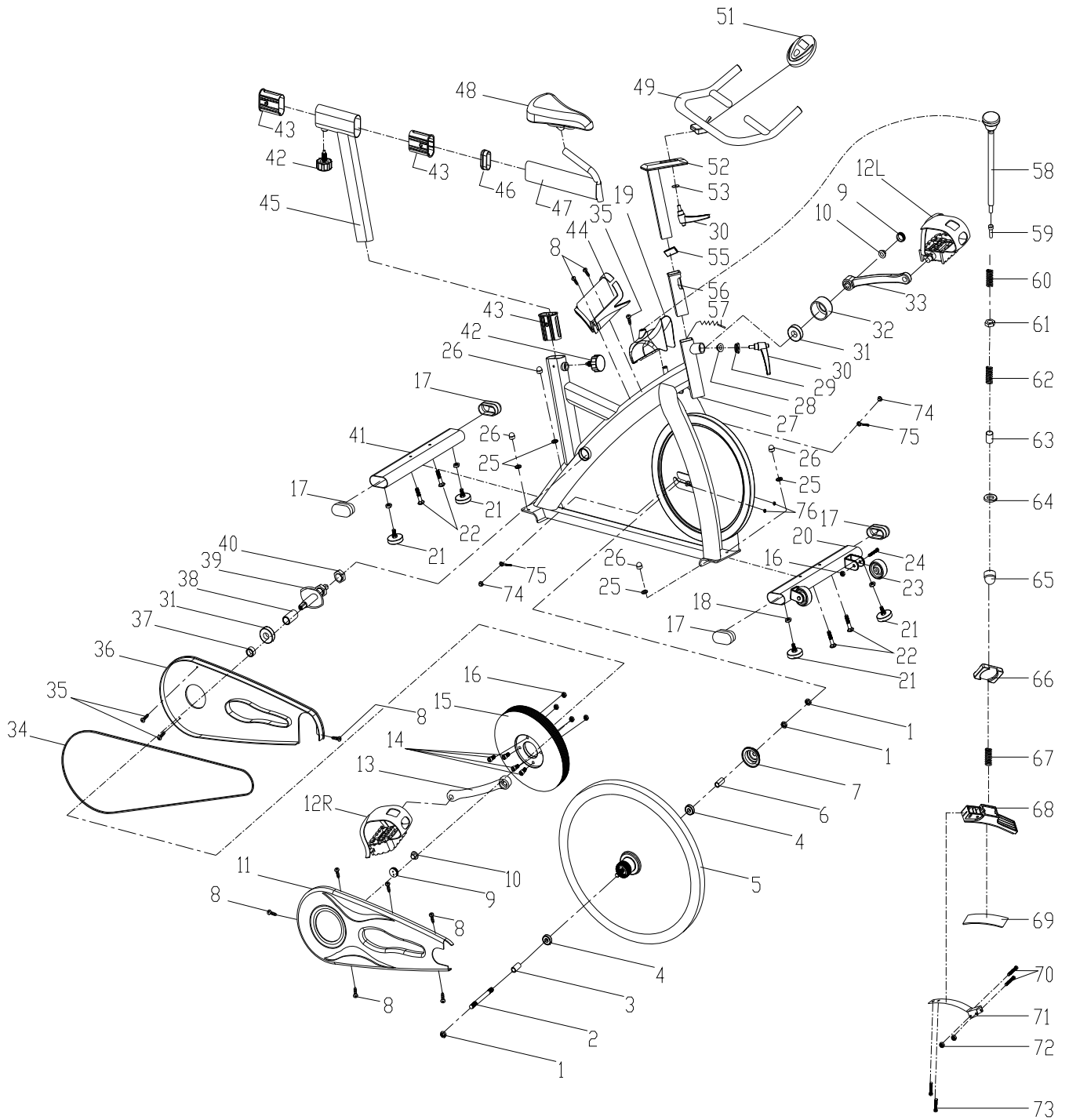

MONITOR INSTRUCTION

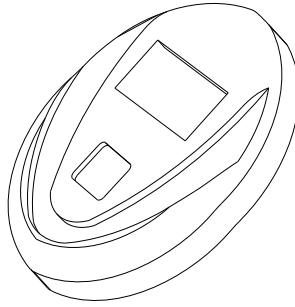

FUNCTION BUTTON

Mode: Press to select functions between: time, speed, distance, calories and scan.
Press and hold for 3 seconds to reset all values to zero.

FUNCTION:

Time: Displays your elapsed workout time up to 99:59

Speed: Displays the current speed up to 99.9 km.

Distance: Displays the cumulative distance traveled during your workout up to 99.9KM

Calorie Displays the cumulative calories burned at any given time during your workout up to 999 kcal.

Note: This is a rough guide used for comparison of different exercise sessions, which cannot be used for medical purposes.

Scan: Displays each function in sequence every 4 seconds. The display loop is time, speed, distance and calories.

NOTE

1. Monitor requires two "AAA" batteries
2. The monitor will turn on automatically by pressing any key or when you start pedaling.
3. The monitor will turn off automatically if no signal is detected for four minutes.
4. If monitor is illegible or partial segments appear, remove batteries and wait 15 seconds to re-install.

TROUBLE SHOOTING

Problem	Cause	Correction
Monitor does not display	Batteries weak or dead	Replace batteries
No speed or distance displays on the monitor	Sending unit not connected	Securely plug sending unit into extension wire and the back of the monitor
	Sending unit not working properly	Replace sending unit
	Monitor not working properly	Replace monitor
Squealing	Brake pads are worn	Replace the brake pads

Maintenance

The safety of this produce can be maintained only if regular periodic checks are made. Most checks can be performed once a week. However some checks should be made before each workout, and are indicated as such below.

Checks

- Be sure batteries are new and electronic connection are clean and tight.
- Check that seat nuts are secure, check before each workout.
- Check that pedals are tight, pedals can work loose over time.
- Check that stabilizer bolts are tight, check before each workout this.
- Check that handlebar is secure, if not, tighten, check before each workout this.
- Should a part become defective, replace it immediately. Do not allow use of the equipment until it has been repaired.

Cleaning

Almost all surfaces are washable. A damp cloth is sufficient to clean most surfaces of this unit. Be careful not to drip water on the monitor. A mild liquid soap may be added if needed.

Always ensure batteries are fresh and in correctly.

How to replace the brake pad

1. Turn the tension/brake knob (58) counter-clockwise to decrease the tension.
2. Remove the hex head bolt (73).
3. Pull up the tension/brake knob (58) to be able to remove the adjustable plate (71).
4. Remove the brake pads (69) from Brake holder (68) and replace with new brake pad using two way tape. It will take a few hours to set.
5. Pull up the tension knob (58) to insert the adjustable plate (71).
6. Secure the hex head bolt (73) that you previously removed.

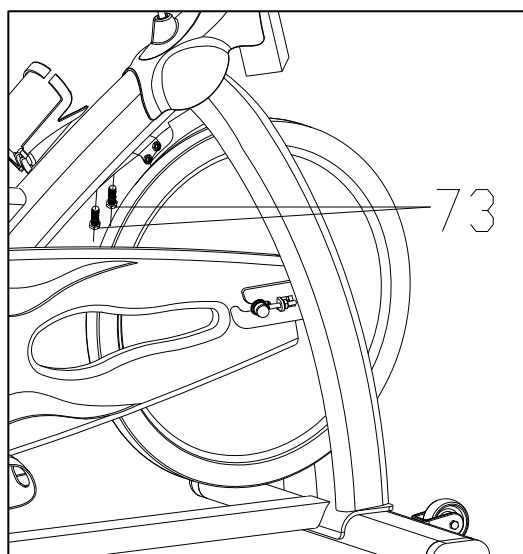
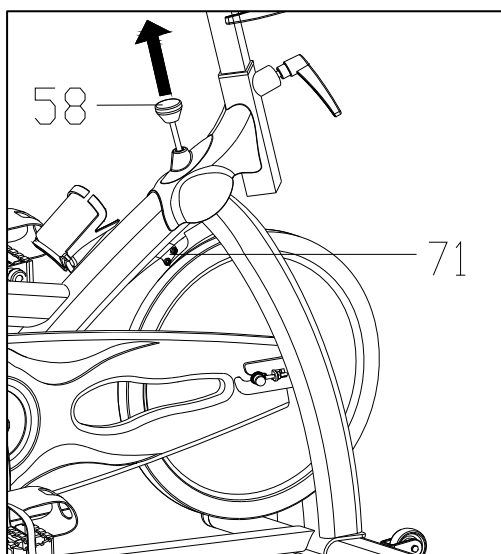
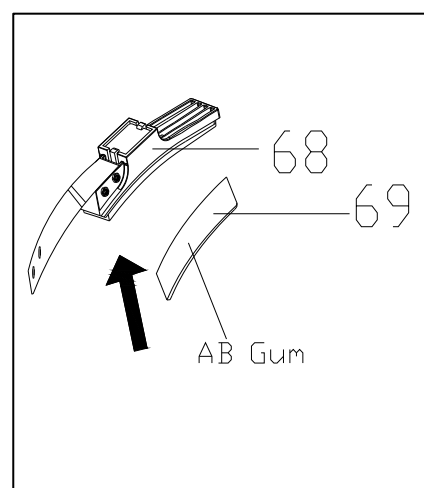
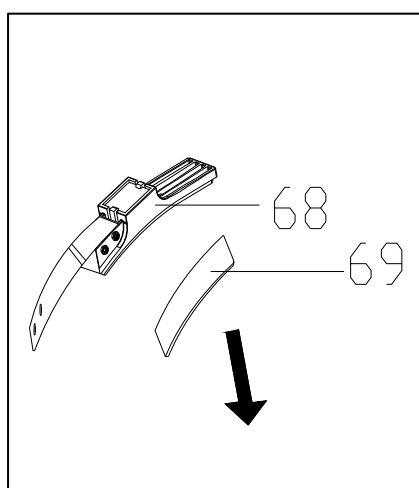
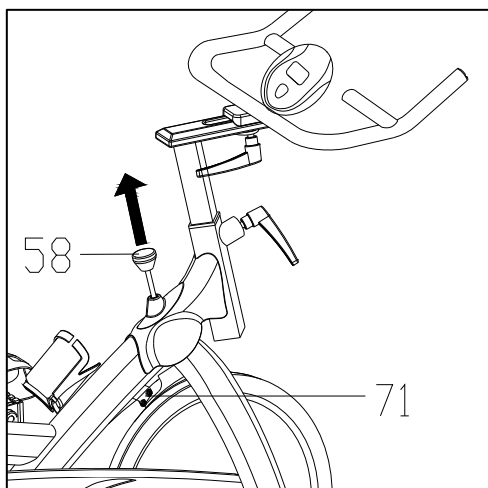
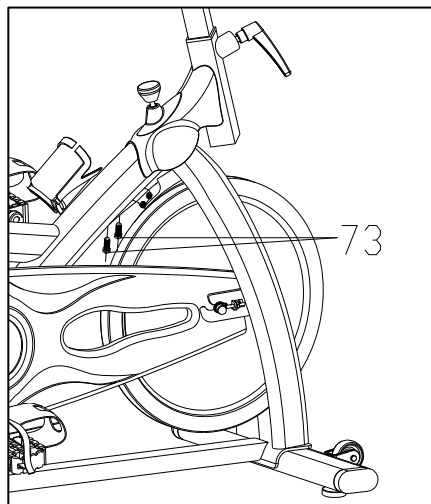
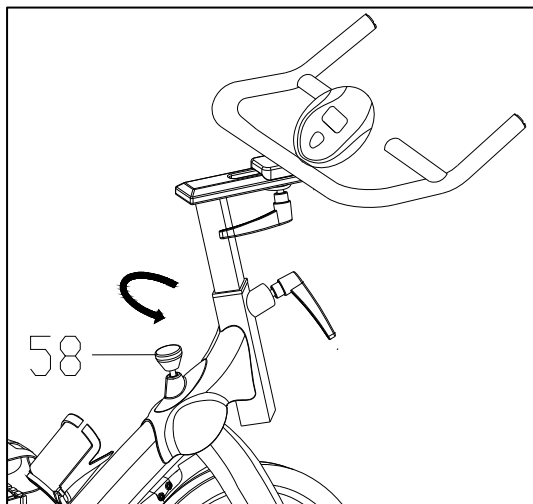

TRAINING GUIDELINES

Exercise

Exercise is one of the most important factors in the overall health of an individual. Listed among its benefits are:

- Increased capacity for physical work (strength endurance)
- Increased cardiovascular (heart and arteries/veins) and respiratory efficiency
- Decreased risk of coronary heart disease
- Changes in body metabolism, e.g. losing weight
- Delaying the physiological effects of age
- Physiological effects, e.g. reduction in stress, increase in self-confidence, etc.

Basic Components of Physical Fitness

There are four all encompassing components of physical fitness and we need to briefly define each and clarify its role.

Strength is the capacity of a muscle to exert a force against resistance. Strength contributes to power and speed and is of great importance to a majority of sports people.

Muscular Endurance is the capacity to exert a force repeatedly over a period of time, e.g. it is the capacity of your legs to carry you 10 Km without stopping.

Flexibility is the range of motion about a joint. Improving flexibility involves the stretching of muscles and tendons to maintain or increase suppleness, and provides increased resistance to muscle injury or soreness.

Cardio-Respiratory Endurance is the most essential component of physical fitness. It is the efficient functioning of the heart and lungs

Aerobic Fitness

The largest amount of oxygen that you can use per minute during exercise is called your **maximum oxygen uptake** (MVO₂). This is often referred to as your **aerobic capacity**.

The effort that you can exert over a prolonged period of time is limited by your ability to deliver oxygen to the working muscles. Regular vigorous exercise produces a training effect that can increase your aerobic capacity by as much as 20 to 30%. An increased MVO₂ indicates an increased ability of the heart to pump blood, of the lungs to ventilate oxygen and of the muscles to take up oxygen.

Anaerobic Training

This means "without oxygen" and is the output of energy when the oxygen supply is insufficient to meet the body's long term energy demands. (For example, 100 meter sprint).

The Training Threshold

This is the minimum level of exercise which is required to produce significant improvements in any physical fitness parameter.

Progression

As you become fitter, a higher intensity of exercise is required to create an overload and therefore provide continued improvement

Overload

This is where you exercise at a level above that which can be carried out comfortably. The intensity, duration and frequency of exercise should be above the training threshold and should be gradually increased as the body adapts to the increasing demands. As your fitness level improves, so the training threshold should be raised.

Working through your program and gradually increasing the overload factor is important.

Specificity

Different forms of exercise produce different results. The type of exercise that is carried out is specific both to the muscle groups being used and to the energy source involved.

There is little transfer of the effects of exercise, i.e. from strength training to cardiovascular fitness. That is why it is important to have an exercise program tailored to your specific needs.

Reversibility

If you stop exercising or do not do your program often enough, you will lose the benefits you have gained. Regular workouts are the key to success.

Warm Up

Every exercise program should start with a **warm up** where the body is prepared for the effort to come. It should be gentle and preferably use the muscles to be involved later.

Stretching should be included in both your **warm up** and **cool down**, and should be performed after 3-5 minutes of low intensity aerobic activity or callisthenic type exercise.

Warm Down or Cool Down

This involves a gradual decrease in the intensity of the exercise session. Following exercise, a large supply of blood remains in the working muscles. If it is not returned promptly to the central circulation, pooling of blood may occur in the muscles

Heart Rate

As you exercise, so the rate at which your heart beat also increases. This is often used as a measure of the required intensity of exercise. You need to exercise hard enough to condition your circulatory system, and increase your pulse rate, but not enough to strain your heart.

Your initial level of fitness is important in developing an exercise program for you. If you are starting off, you can get a good training effect with a heart rate of 110-120 beats per minute(BPM). If you are fitter, you will need a higher threshold of stimulation.

To begin with, you should exercise at a level that elevates your heart rate to about 65 to 70% of your maximum. If you find this is too easy, you may want to increase it, but it is better to lean on the conservative side.

As a rule of thumb, the maximum heart rate is 220 minus your age. As you increase in age, so your heart, like other muscles, loses some of its efficiency. Some of its natural loss is won back as fitness improves.

The following table is a guide to those who are "starting fitness".

Age	25	30	35	40	45	50	55	60	65
Target heart Rate									
10 Second Count	23	22	22	21	20	19	19	18	18
Beats per Minute	138	132	132	126	120	114	114	108	108

Pulse Count

The pulse count(on your wrist or carotid artery in the neck, taken with two index fingers)is done for ten seconds, taken a few seconds after you stop exercising. This is for two reasons: (a) 10 seconds is long enough for accuracy, (b) the pulse count is to approximate your BPM rate at the time you are exercising. Since heart rate slows as you recover, a longer count isn't as accurate.

The target is not a magic number, but a general guide. If you're above average fitness, you may work quite comfortably a little above that suggested for your age group.

The following table is a guide to those who are keeping fit. Here we are working at about 80% of maximum.

Age	25	30	35	40	45	50	55	60	65
Target heart Rate									
10 Second Count	26	26	25	24	23	22	22	21	20
Beats per Minute	156	156	150	144	138	132	132	126	120

Don't push yourself too hard to reach the figures on this table. It can be very uncomfortable if

you overdo it. Let it happen naturally as you work through your program. Remember, the target is a guide, not a rule, a little above or below is just fine.

Two final comments:(1) don't be concerned with day to day variations in your pulse rate, being under pressure or not enough sleep can affect it;(2) your pulse rate is a guide, don't become a slave to it.

Endurance Circuit Training

Cardiovascular endurance, muscle, strength, flexibility and coordination are all necessary for maximum fitness. The principle behind circuit training is to give a person all the essentials at one time by going through your exercise program moving as fast as possible between each exercise. This increases the heart rate and sustains it, which improves the fitness level. Do not introduce this circuit training effect until you have reached an advanced program stage.

Body Building

Is often used synonymously with strength training The fundamental principal here is OVERLOAD. Here, the muscle works against greater loads than usual. This can be done by increasing the load you are working against.

Patronization

This is the term used to vary your exercise program for both physiological and psychological benefits. In your overall program, you should vary the workload, frequency and intensity. The body responds better to variety and so do you. In addition, when you feel yourself getting "stale", bring in periods of lighter exercise to allow the body to recuperate and restore its reserves. You will enjoy your program more and feel better for it.

Muscle Soreness

For the first week or so, this may be the only indication you have that you are on an exercise program. This, of course, does depend on your overall fitness level. A confirmation that you are on the correct program is a very slight soreness in most major muscle groups. This is quite normal and will disappear in a matter of days.

If you experience major discomfort, you may be on a program that is too advanced or you have increased your program too rapidly.

If you experience PAIN during or after exercise, your body is telling you something. Stop exercising and consult your doctor.

What to Wear

Wear clothing that will not restrict your movement in any way while exercising. Clothes should be light enough to allow the body to cool. Excessive clothing that causes you to perspire more than you normally would while exercising, gives you no advantage. The extra weight you lose is body fluid and will be replaced with the next glass of water you drink. It is advisable to wear a pair of gym or running shoes or "sneakers".

Breathing during Exercise

Do not hold your breath while exercising. Breathe normally as much as possible. Remember, breathing involves the intake and distribution of oxygen, which feeds the working muscles.

Rest periods

Once you start your exercise program, you should continue through to the end. Do not break off halfway through and then restart at the same place later on without going through the warm-up stage again.

The rest period required between strength training exercises may vary from person to person. This will depend mostly on your level of fitness and the program you have chosen. Rest between exercises by all means, but do not allow this to exceed two minutes. Most people manage with half minute to one minute rest periods

STRETCHING

Stretching should be included in both your warm up and cool down, and should be performed after 3-5 minutes of low intensity aerobic activity or callisthenic type exercise. Movements should be performed slowly and smoothly, with no bouncing or jerking. Move into the stretch until slight tension, not pain, is felt in the muscle and hold for 20-30 seconds. Breathing should be slow, rhythmical and under control, making sure never to hold your breath.

HEAD ROLLS

Rotate your head to the right for one count, feeling the stretch up the left side of your neck. Next rotate your head back for one count, stretching your chin to the ceiling and letting your mouth open. Rotate your head to the left for one count, and finally, drop your head to your chest for one count.

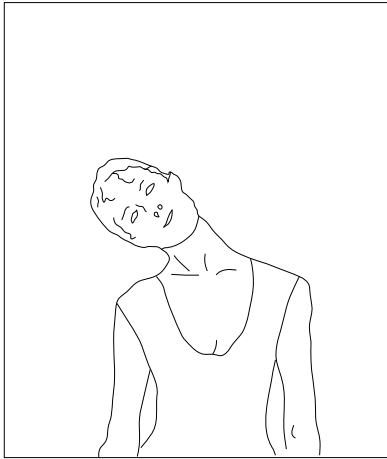

SHOULDER LIFTS

Lift your right shoulder up toward your ear for one count. Then lift your left shoulder up for one count as you lower your right shoulder.

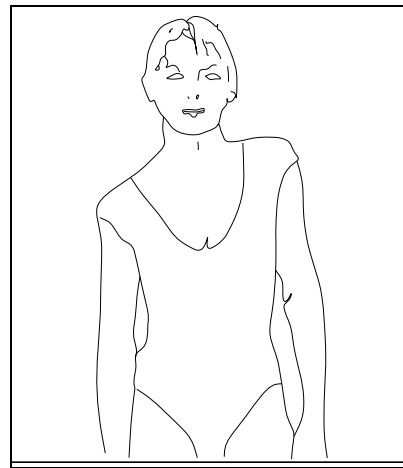

SIDE STRETCHES

Open your arms to the side and continue lifting them until they are over your head. Reach your right arm as far upward toward the ceiling as you can for one count. Feel the stretch up your right side. Repeat this action with your left arm.

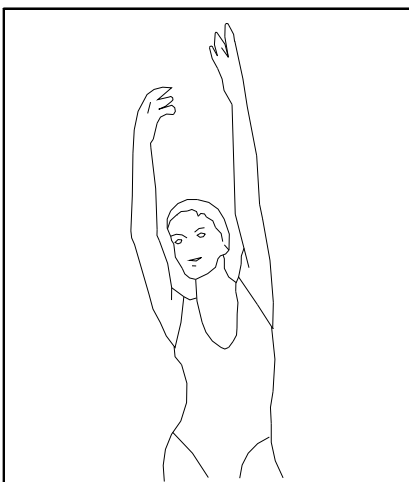

QUADRICEPS STRETCH

With one hand against a wall for balance, reach behind you and pull your right foot up. Bring your heel as close to your buttocks as possible. Hold for 15 counts and repeat with left foot up.

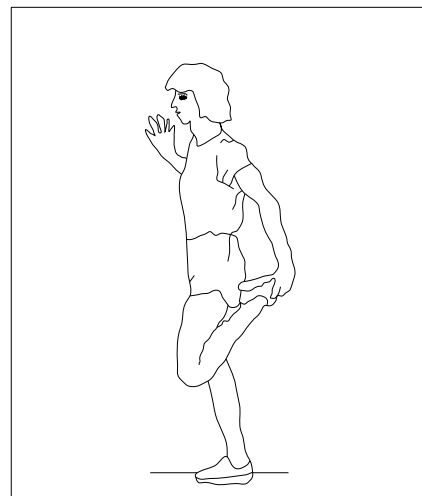

INNER THIGH STRETCH

Sit with the soles of your feet together with your knees pointing outward. Pull your feet as close into your groin as possible. Gently push your knees towards the floor. Hold for 15 counts.

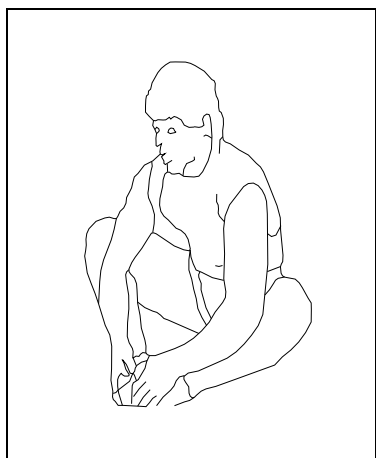

TOE TOUCHES

Slowly bend forward from your waist, letting your back and shoulders relax as you stretch toward your toes. Reach down as far as you can and hold for 15 counts.

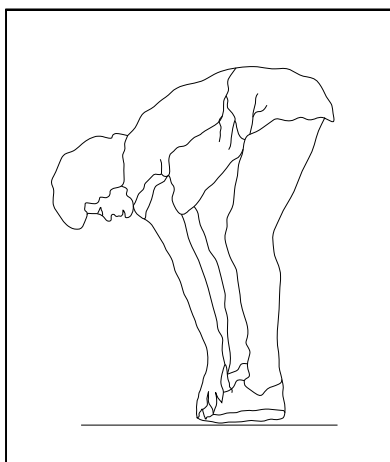

HAMSTRING STRETCHES

Sit with your right leg extended. Rest the sole of your left foot against your right inner thigh. Stretch your toe as far as possible. Hold for 15 counts. Relax and then repeat with left leg extended.

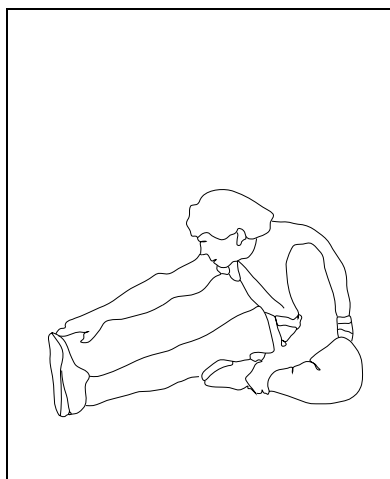

CALF / ACHILLES STRETCH

Lean against a wall with your left leg in front of the right and your arms forward. Keep your right leg straight and the left foot on the floor then bend the left leg and lean forward by moving your hips toward the wall. Hold, then repeat on the other side for 15 counts.

